

MLPC

Технические характеристики

По вопросам продаж и поддержки обращайтесь:

Алматы (7273)495-231	Казань (843)206-01-48	Новокузнецк (3843)20-46-81	Смоленск (4812)29-41-54
Архангельск (8182)63-90-72	Калининград (4012)72-03-81	Новосибирск (383)227-86-73	Сочи (862)225-72-31
Астрахань (8512)99-46-04	Калуга (4842)92-23-67	Омск (3812)21-46-40	Ставрополь (8652)20-65-13
Барнаул (3852)73-04-60	Кемерово (3842)65-04-62	Орел (4862)44-53-42	Сургут (3462)77-98-35
Белгород (4722)40-23-64	Киров (8332)68-02-04	Оренбург (3532)37-68-04	Тверь (4822)63-31-35
Брянск (4832)59-03-52	Краснодар (861)203-40-90	Пенза (8412)22-31-16	Томск (3822)98-41-53
Владивосток (423)249-28-31	Красноярск (391)204-63-61	Пермь (342)205-81-47	Тула (4872)74-02-29
Волгоград (844)278-03-48	Курск (4712)77-13-04	Ростов-на-Дону (863)308-18-15	Тюмень (3452)66-21-18
Вологда (8172)26-41-59	Липецк (4742)52-20-81	Рязань (4912)46-61-64	Ульяновск (8422)24-23-59
Воронеж (473)204-51-73	Магнитогорск (3519)55-03-13	Самара (846)206-03-16	Уфа (347)229-48-12
Екатеринбург (343)384-55-89	Москва (495)268-04-70	Санкт-Петербург (812)309-46-40	Хабаровск (4212)92-98-04
Иваново (4932)77-34-06	Мурманск (8152)59-64-93	Саратов (845)249-38-78	Челябинск (351)202-03-61
Ижевск (3412)26-03-58	Набережные Челны (8552)20-53-41	Севастополь (8692)22-31-93	Череповец (8202)49-02-64
Иркутск (395)279-98-46	Нижний Новгород (831)429-08-12	Симферополь (3652)67-13-56	Ярославль (4852)69-52-93
Россия (495)268-04-70	Киргизия (996)312-96-26-47	Казахстан (7172)727-132	

SURGE PROTECTORS FOR LED LIGHTING SYSTEM

MLPC SERIES



- Type 2 (or 3) surge protectors for Led lighting
- Very compact
- Plate mounting
- VG technology version
- Screw terminal or spring terminal connection
- Status indicator
- End of life AC Disconnection
- IEC 61643-11 and EN 61643-11 certification

Characteristics



CITEL Model		MLPC1-230L-*	MLPC-VG1-230L-*	MLPC2-230L-R	MLPC-VG2-230L-*
Description		Surge protector Type2 (or 3) for LED lighting			
Application		Class I LED system	Class I LED system	Class II LED system	Class II LED system
Network		220-240 V single phase	220-240 V single phase	220-240 V single phase	220-240 V single phase
AC system		TT/TN	TT/TN	TT/TN	TT/TN
Protection mode(s)		CM/DM*	CM/DM*	DM*	DM*
Max. AC operating voltage	Uc	320 Vac	320 Vac	320 Vac	320 Vac
Max. Load current	IL	5 A	10 A	5 A	10 A
Residual current - Leakage current at Uc	Ipe	none	none	none	none
Temporary Over Voltage (TOV) Characteristics - 5 sec.	UT	335 Vac withstand	335 Vac withstand	335 Vac withstand	335 Vac withstand
Temporary Over Voltage (TOV) Characteristics - 120 mn	UT	440 Vac disconnection	440 Vac withstand	440 Vac disconnection	440 Vac disconnection
Temporary Over Voltage N/PE (TOV HT)	UT	1200 V/300A/200 ms disconnection	1200 V/300A/200 ms disconnection	-	-
Nominal discharge current - 15 x 8/20 μ s impulses	In	5 kA	5 kA	5 kA	5 kA
Max. discharge current - max. withstand @ 8/20 μ s by pole	Imax	10 kA	10 kA	10 kA	10 kA
Total discharge current - max. total withstand @ 8/20 μ s	Imax total	20 kA	20 kA	20 kA	20 kA
Withstand on Combination waveform - Class III test	Uoc	10 kV	10 kV	10 kV	10 kV
Protection level L/N @In (8/20 μ s)	Up	1.5 kV	1.5 kV	1.5 kV	1.5 kV
Protection level N/PE @In (8/20 μ s)	Up	1.5 kV	1.5 kV	-	-
Admissible short-circuit current	Iscsr	10000 A	10000 A	10000 A	10000 A
Associated disconnectors					
Thermal disconnector		internal			
Installation ground fault breaker		Type "S" or delayed			
Mechanical characteristics					
Dimensions		see diagram			
Connection to Network		Screw (2.5 mm ² max) or Spring (1.5 mm ² max) contact terminal		2 spring terminals opposite side in/out - wire 1.5 mm ² max.	Screw (2.5 mm ² max) or Spring (1.5 mm ² max) contact terminal
Voltage/operating indicator		Green Led ON			
Disconnection indicator		Led green OFF and AC network cut-off			
Failsafe behavior		Disconnection and AC network cut-off			
Mounting		on plate			
Operating temperature		-40/+85°C			
Protection rating		IP20			
Housing material		Thermoplastic UL94 V-0			
Standards					
Certification		EN 61643-11 / IEC 61643-11			
Model/Part number					
version Spring contact / 2 opposed terminals		MLPC1-230L-R 831211	MLPC-VG1-230L-R 836211	MLPC2-230L-R 832211	MLPC-VG2-230L-R 837211
version Screw terminal / 2 opposed terminals		MLPC1-230L-V 831221	MLPC-VG1-230L-V 836221	-	MLPC-VG2-230L-V 837221
version Spring contact / 1 common terminal		MLPC1-230L-R/50 831212	-	-	-
version Screw terminal / 1 common terminal		MLPC1-230L-V/50 831222	-	-	-

SURGE PROTECTORS FOR LED LIGHTING SYSTEM

MLPC-VG1-230L-V/50

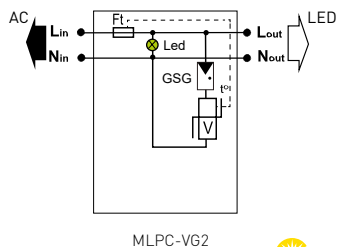
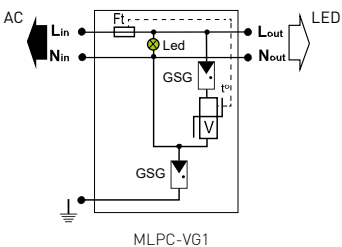
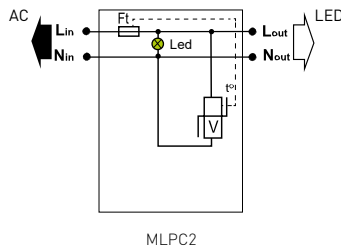
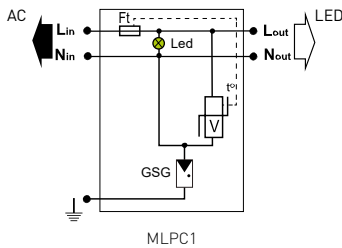
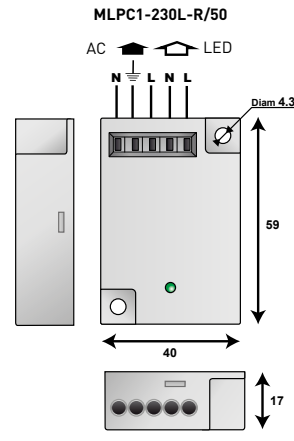
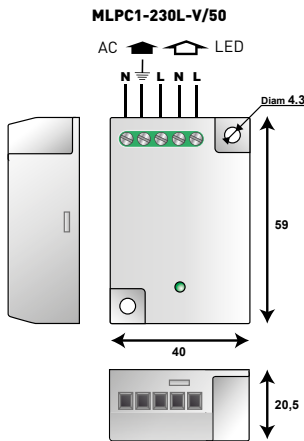
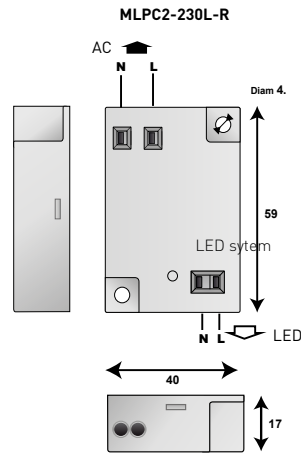
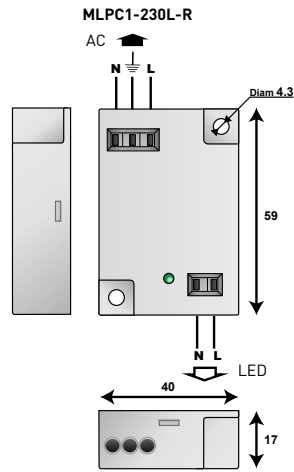
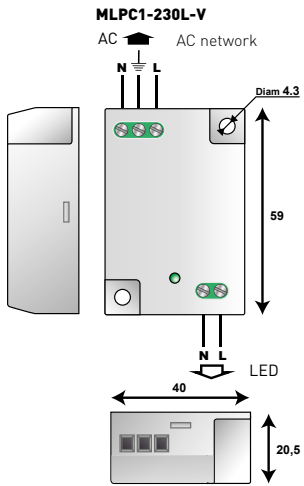
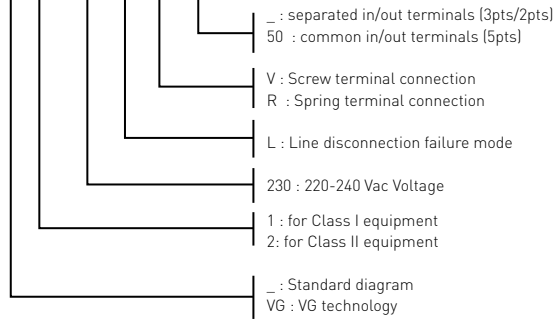

Ft: Thermal fuse
 Led: Disconnection indicator
 V: Varistor
 GSG: Specific Gas Tube
 t°: Thermal disconnection system

MLPC1-230L-V/2L



- Compact Type 2 (or 3) surge protector
- For Classe I
- 2-phases+Neutral network
- Screw connection
- I_{max} : 10 kA
- EN 61643-11, IEC 61643-11 compliance

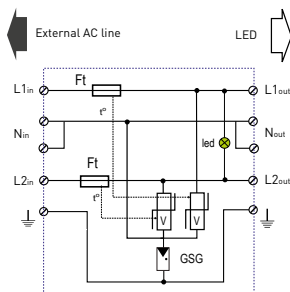
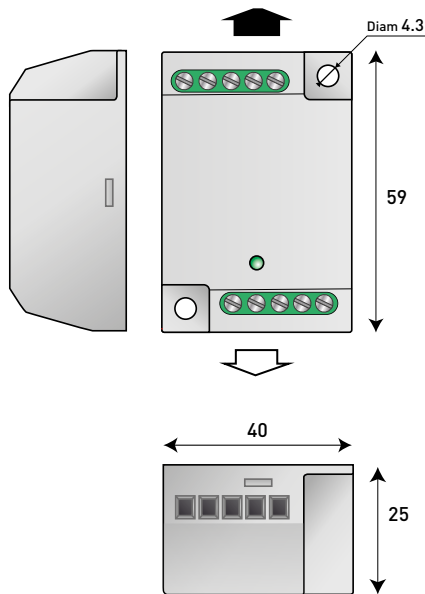

Ft: Thermal fuse
 Led: Disconnection indicator
 V: Varistor
 GSG: Specific Gas Tube
 t°: Thermal disconnection system

Characteristics

CITEL model	MLPC1-230L-V/2L	
Description	AC surge protector for LED lighting	
Application	LED Classe I	
Network	230 V 2-phases+Neutral	
AC system	TT-TN	
Protection model(s)	L1/N, L2/N and N/PE	
Max. AC operating voltage	U _c	320 Vac
Max. load current	I _L	5 A
Residual current - leakage current at U _c	I _{pe}	none
Temporary Over Voltage characteristics (TOV) 5sec.	UT	335 Vac withstand
Temporary Over Voltage characteristics (TOV) 120 mn.	UT	440 Vac disconnection
Nominal discharge current <i>15 x 8/20μs</i>	I _n	5 kA
Maximum discharge current <i>max. withstand 8/20 μs</i>	I _{max}	10 kA
Withstand on combination waveform <i>1,2/50μs-8/20μs</i>	U _{oc}	10 kV / 5 kA
Protection level L/N @In (8/20 μ s)	U _p	1.5 kV
Protection level N/PE @In (8/20 μ s)	U _p	1.5 kV
Admissible short-circuit current	I _{scrr}	10 000 A
Associated disconnectors		
Thermal disconnector	internal	
Mechanical characteristics		
Dimensions	see diagram	
Connection to network	Screw connection: 1,5 mm ² max	
Voltage/operating indicator	Green Led ON	
Failsafe behavior	Disconnection, Green Led OFF and AC line cut-off	
Mounting	on plate	
Operating temperature	-40/+85°C	
Protection rating	IP20	
Housing material	Thermoplastic UL94 V-0	
Standards		
Conforme	EN 61643-11 / IEC 61643-11	
Part number		
	831225	

MLPC1-230L-V/DL



- Type 2 (or 3) surge protector for Class 1 LED lighting
- Combined AC/Dateline surge protection
- DALI, DMX, RS485, 0-10V dataline compliance
- Shield wire management
- Optimized coordination with driver (option: MLPCH1-230L-V/DL)
- Screw connection
- I_{max} : 10 kA
- EN 61643-11, IEC 61643-11 compliance

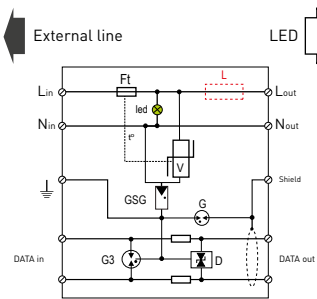
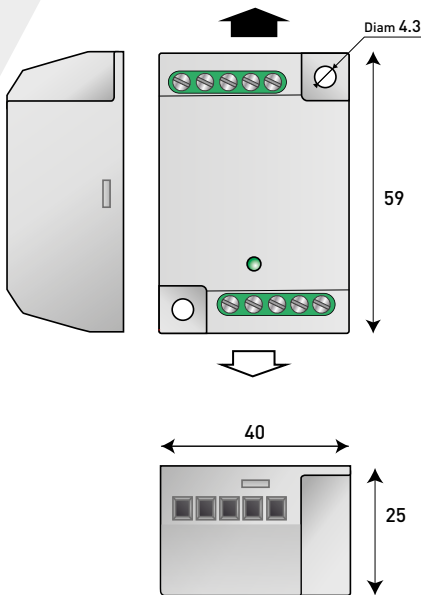

V : Varistor
 Ft : Thermal fuse
 GSG : Specific gas tube
 G : 2-electrode gas tube
 G3 : 3-electrode gas tube
 D : Clamping diode
 L : Coordination inductor (option)
 LED : Status indicator

Characteristics

CITEL model	MLPC1-230L-V/DL
Description	AC/Dateline SPD for LED lighting system Class 1
AC power Characteristic	
Network	230 V single phase
AC system	TT-TN
Protection mode(s)	L/N and N/PE
Max. AC operating voltage	Uc 320 Vac
Max. Load current	IL 5 A (2,5 A)*
Residual current - Leakage current at Uc	Ipe None
Temporary over voltage (TOV) characteristics 5sec.	UT 335 Vac withstand
Temporary over voltage (TOV) characteristics 120 mn.	UT 440 Vac disconnection
Nominal discharge current - 15 x 8/20µs impulses	In 5 kA
Max. discharge current - max. withstand @ 8/20 µs	I _{max} 10 kA
Withstand on Combination waveform	Uoc 10 kV / 5 kA
Protection level L/N @In (8/20µs)	Up 1.5 kV
Protection level N/PE @In (8/20µs)	Up 1.5 kV
Admissible short-circuit current	I _{scrr} 10 000 A
Thermal disconnectors	internal
Connection to network	Screw connection : 1,5 mm ² max
Voltage/operating indicator	Green Led ON
Failsafe behavior	Disconnection, Green Led OFF and AC line cut-off
Specific version for optimized coordination with driver	MLPCH1-230L-V/DL*
Dateline Characteristics	
Network	DALI/DMX/RS485/0-10V
Dateline configuration	1-pair + shield
Nominal line voltage	Un 24 V
Max. DC operating voltage	Uc 28 V
Max. Load current	IL 300 mA
Max. frequency	f max 10 mHz
Insertion loss	< 1 dB
Nominal discharge current - 15 x 8/20µs impulses	In 5 kA
Max. discharge current - max withstand @ 8/20µs	I _{max} 10 kA
Protection level L/L or L/PE	Up 50 V
Protection level Shield/PE	Up < 600V
Connection to network	Screw connection: 1,5 mm ² max
Failure indication	Transmission cut-off
Mechanical Characteristics	
Dimensions	see diagram
Mounting	on plate
Operating temperature	-40/+85°C
Protection rating	IP20
Housing material	Thermoplastic UL94 V-0
Standards	
Compliance	EN 61643-11 / IEC 61643-11
Part number	
	831225



- ↳ Type 2 (or 3) surge protectors for LED
- ↳ Class 1
- ↳ Very compact
- ↳ Plate mounting
- ↳ Spring terminal connection
- ↳ Status indicator
- ↳ Disconnection AC end of life
- ↳ EN 61643-11 compliance

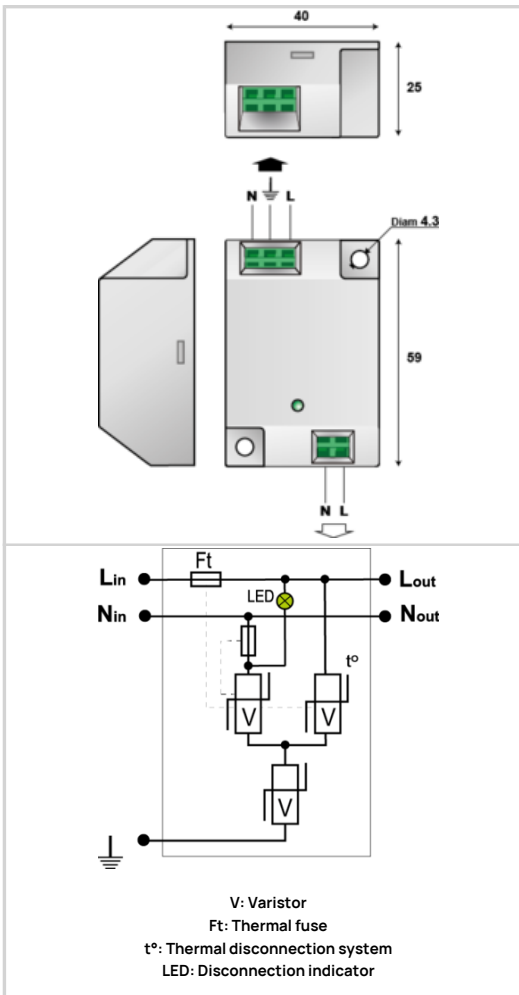

Electrical Characteristics		
SPD type (following IEC tests)		2+3
Network		220-240 V single-phase
AC system		IT
Max. AC operating voltage	Uc	440 Vac
Max. load current	IL	10 A
Temporary Over Voltage (TOV) Characteristics - 5 sec. (Without disconnection)	UT	335 Vac withstand
Temporary Over Voltage (TOV) Characteristics - 120 mn (Without disconnection or with safety disconnection)	UT	440 Vac withstand
Residual Current (Leakage current to Ground)	Ipe	< 1 mA
Nominal discharge current (15 x 8/20 μs impulses)	In	5 kA
Max. discharge current (max. withstand @ 8/20 μs by pole)	Imax	10 kA
Total Maximum discharge current (max. total withstand @ 8/20 μs)	Imax Total	20 kA
Withstand on Combination waveform IEC 61643-11 (Class III test: 1.2/50μs - 8/20μs)	Uoc	10 kV
Withstand on overvoltages IEEE C62.41.1		10 kV / 10 kA
Protection level L/N (@ In (8/20μs))	Up L/N	1.5 kV
Protection level L/PE (@ In (8/20μs))	Up L/PE	1.8 kV
Admissible short-circuit current	Iscrr	10 000 A
Mechanical Characteristics		
Technology		MOV
Connection to Network		2 spring terminals opposite side in/out - wire 2.5 mm ² max.
Mounting		On plate
Housing material		Thermoplastic UL94 V-0
Operating temperature	Tu	-40/+85°C
Protection rating		IP20
Failsafe mode		Disconnection and AC line cut-off
Disconnection indicator		Led green OFF and AC network cut-off
Voltage/operating indicator		Green Led ON
Dimensions		See diagram
Disconnectors		
Thermal disconnector		Internal
Installation ground fault breaker		Type 'S' or delayed
Standards		
Standards compliance		EN 61643-11 / IEC 61643-11
Part number		
831431		

MLPC2/ESP2 & ESP-230



- Type 2 (or 3) Surge & Electrostatic protectors
- For Class II Led lighting
- Version Electrostatic protector only: ESP-230
- Electrostatic protection included: MLPC2
- Plate mounting
- Screw terminal or spring terminal connection
- Status indicator
- End of life AC Disconnection
- IEC 61643-11 and EN 61643-11 compliance

Characteristics

CITEL Model	MLPC2-230L-V/ESP2	MLPC2-230L-R/ESP2	ESP-230
Description	Surge & Electrostatic protectors for Class II LED lighting		Electrostatic protectors for Class II LED lighting
Network	220-240 V single phase	220-240 V single phase	220-240 V single phase
AC system	TT/TN	TT/TN	TT/TN
Surge Protection mode	L/N	L/N	-
Electrostatic protection mode	N/Functional Earth	N/Functional Earth	N/Functional Earth
Max. AC operating voltage	Uc 320 Vac	320 Vac	320 Vac
Max. Load current	IL 10 A	10 A	-
Residual current leakage current at Uc	Ipe none	none	none
Temporary Over Voltage (TOV) Characteristics - 5 sec.	UT 335 Vac withstand	335 Vac withstand	-
Temporary Over Voltage (TOV) Characteristics - 120 mn	UT 440 Vac disconnection	440 Vac disconnection	-
Nominal discharge current 15 x 8/20 μs impulses	In 5 kA	5 kA	-
Max. discharge current max. withstand 8/20 μs by pole	I _{max} 10 kA	10 kA	-
Withstand on Combination waveform - Class III test	Uoc 10 kV	10 kV	10 kV
Protection level L/N @In (8/20μs)	Up 1.5 kV	1.5 kV	-
Electrostatic protection level	UESP > 0.5 kV	> 0.5 kV	> 0.5 kV
Admi. short-circuit current	Iscrr 10000 A	10000 A	-
Associated disconnectors			
Thermal disconnector	internal		
Installation ground fault breaker	Type «S» or delayed		
Mechanical characteristics			
Dimensions	see diagram		
Connection to Network	2 screw terminals opposite side in/out - wire 2.5 mm ² max.	2 spring terminals opposite side in/out Wire 1.5 mm ² max.	2 wires 1 mm ²
Voltage/operating indicator	Green Led ON		
Failsafe behavior	Disconnection and AC network cut-off		
Disconnection indicator	Led green OFF and AC network cut-off		
Mounting	on plate		
Operating temperature	-40/+85°C		
Protection rating	IP20		
Housing material	Thermoplastic UL94 V-0		
Standards			
Compliance	EN 61643-11 / IEC 61643-11		-
Part number			
	832227	832217	354913

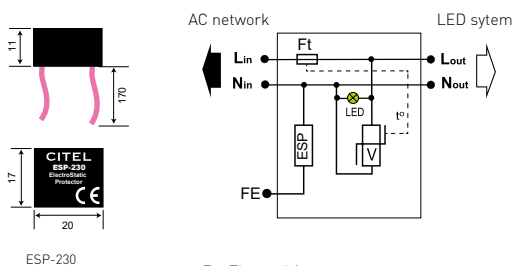
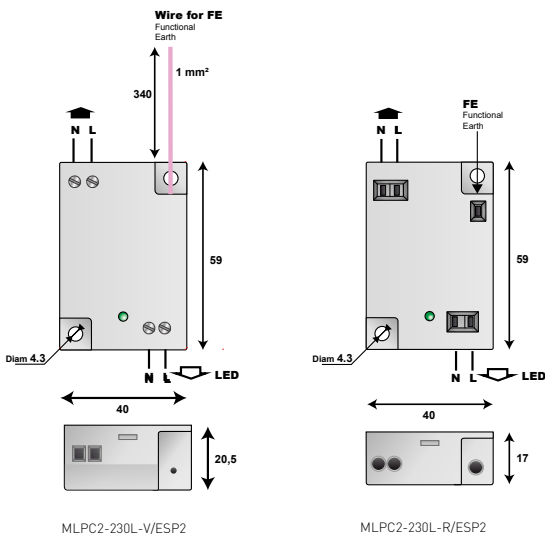

Ft : Thermal fuse
 Led : Status indicator
 V : MOV
 t°: Thermal disconnection system
 ESP: Electrostatic protection
 FE: Functional Earth

MLPCH1-230L-R



- Type 2 (or 3) surge protectors for LED
- Class 1
- Very compact
- Plate mounting
- Spring terminal connection
- Status indicator
- Disconnection AC end of life
- EN 61643-11 compliance



Electrical Characteristics		
SPD type (following IEC tests)		2+3
Network		230-277 V single-phase
AC system		TT/TN
Max. AC operating voltage	Uc	320 Vac
Max. load current	IL	2.5 A
Temporary Over Voltage (TOV) Characteristics - 5 sec. (Without disconnection)	UT	335 Vac withstand
Temporary Over Voltage (TOV) Characteristics - 120 mn (Without disconnection or with safety disconnection)	UT	440 Vac disconnection
Temporary Over Voltage N/PE (TOV HT) (Without disconnection or with safety disconnection)	UT	1200 V/300A/200 ms disconnection
Nominal discharge current (15 x 8/20 µs impulses)	In	5 kA
Max. discharge current (max. withstand @ 8/20 µs by pole)	Imax	10 kA
Total Maximum discharge current (max. total withstand @ 8/20 µs)	Imax Total	20 kA
Withstand on Combination waveform IEC 61643-11 (Class III test: 1.2/50µs - 8/20µs)	Uoc	10 kV
Withstand on overvoltages IEEE C62.41.1		10 kV / 10 kA
Protection mode(s)		Common/Differential mode
Protection level L/N (@ In (8/20µs))	Up L/N	1.5 kV
Protection level L/PE (@ In (8/20µs))	Up L/PE	1.5 kV
Admissible short-circuit current	Iscrr	10 000 A
Mechanical Characteristics		
Technology		MOV+GDT
Connection to Network		by spring - max. cross section 1.5 mm ²
Mounting		On plate
Housing material		Thermoplastic UL94 V-0
Operating temperature	Tu	-40/+85°C
Protection rating		IP20
Failsafe mode		Disconnection and AC line cut-off
Disconnection indicator		Led green OFF and AC network cut-off
Voltage/operating indicator		Green Led ON
Dimensions		See diagram
Disconnectors		
Thermal disconnector		Internal
Installation ground fault breaker		Type 'S' or delayed
Standards		
Standards compliance		EN 61643-11 / IEC 61643-11
Certification		UL / EAC / TÜV
Part number		
833211		

MLPCH1-230L-V



- ↳ Type 2 (or 3) surge protectors for LED
- ↳ Optimized coordination with internal MOV of driver
- ↳ Very compact
- ↳ Plate mounting
- ↳ Screw terminal connection
- ↳ Status indicator
- ↳ Disconnection AC end of life
- ↳ IEC 61643-11 and EN 61643-11 compliance



Electrical Characteristics		
SPD type (following IEC tests)		2+3
Network		230-277 V single-phase
AC system		TT/TN
Max. AC operating voltage	Uc	320 Vac
Max. load current	IL	2.5 A
Temporary Over Voltage (TOV) Characteristics - 5 sec. (Without disconnection)	UT	335 Vac withstand
Temporary Over Voltage (TOV) Characteristics - 120 mn (Without disconnection or with safety disconnection)	UT	440 Vac disconnection
Temporary Over Voltage N/PE (TOV HT) (Without disconnection or with safety disconnection)	UT	1200 V/300A/200 ms disconnection
Nominal discharge current (15 x 8/20 µs impulses)	In	5 kA
Max. discharge current (max. withstand @ 8/20 µs by pole)	Imax	10 kA
Total Maximum discharge current (max. total withstand @ 8/20 µs)	Imax Total	20 kA
Withstand on Combination waveform IEC 61643-11 (Class III test: 1.2/50µs - 8/20µs)	Uoc	10 kV
Withstand on overvoltages IEEE C62.41.1		10 kV / 10 kA
Protection mode(s)		Common/Differential mode
Protection level L/N (@ In (8/20µs))	Up L/N	1.5 kV
Protection level L/PE (@ In (8/20µs))	Up L/PE	1.5 kV
Admissible short-circuit current	Iscrr	10 000 A
Mechanical Characteristics		
Technology		MOV+GDT
Connection to Network		Screw contact terminal - wire 2.5 mm ² max.
Mounting		On plate
Housing material		Thermoplastic UL94 V-0
Operating temperature	Tu	-40/+85°C
Protection rating		IP20
Failsafe mode		Disconnection and AC line cut-off
Disconnection indicator		Led green OFF and AC network cut-off
Voltage/operating indicator		Green Led ON
Dimensions		See diagram
Disconnectors		
Thermal disconnector		Internal
Installation ground fault breaker		Type 'S' or delayed
Standards		
Standards compliance		EN 61643-11 / IEC 61643-11
Certification		UL / EAC / TÜV
Part number		
833221		



CITEL MLPCH1-230L-V/DL



- Type 2 (or 3) surge protector for Class 1 LED Lighting
- Combined AC/Dataline surge protection
- DALI, DMX, RS485, 0-10V datalines compliance
- Shield wire management
- Optimized coordination with driver
- Compact dimensions
- Screw connection
- Max. discharge current 10 kA
- IEC 61643-11 and IEC61643-21 compliance

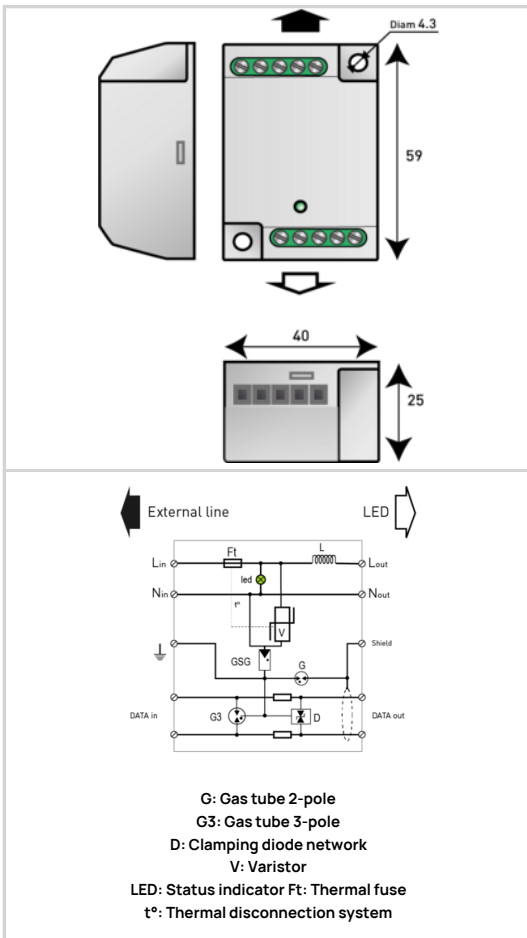

Electrical Characteristics		
Network		230 V single-phase
Max. AC operating voltage	Mcov	320 Vac
Max. load current	IL	2.5 A
Temporary Over Voltage (TOV) Characteristics - 5 sec. (Without disconnection)	UT	335 Vac withstand
Temporary Over Voltage (TOV) Characteristics - 120 mn (Without disconnection or with safety disconnection)	UT	440 Vac disconnection
Residual Current (Leakage current to Ground)	Ipe	None
Nominal discharge current (15 x 8/20 μs impulses)	In	5 kA
Max. discharge current (max. withstand @ 8/20 μs by pole)	I _{max}	10 kA
Withstand on Combination waveform IEC 61643-11 (Class III test: 1.2/50μs - 8/20μs)	Uoc	10 kV / 5 kA
Protection mode(s)		Common/Differential mode
Protection level L/N (@ In (8/20μs))	Up L/N	1.5 kV
Protection level N/PE (@ In (8/20μs))	Up N/PE	1.5 kV
Admissible short-circuit current	I _{sc}	10 000 A
Mechanical Characteristics		
Technology		MOV+GDT
Connection to Network		Screw terminal 1.5 mm ² max
Mounting		On plate
Housing material		Thermoplastic UL94-V0
Operating temperature	Tu	-40/+85°C
Protection rating		IP20
Failsafe mode		Disconnection, Green Led OFF and power cut off
Disconnection indicator		Green Led ON
Dimensions		See diagram
Weight		0.056 kg
Standards		
Standards compliance		IEC 61643-11 / EN 61643-11 / UL1449 ed.4
Part number		
833223		

По вопросам продаж и поддержки обращайтесь:

Алматы (7273)495-231	Казань (843)206-01-48	Новокузнецк (3843)20-46-81	Смоленск (4812)29-41-54
Архангельск (8182)63-90-72	Калининград (4012)72-03-81	Новосибирск (383)227-86-73	Сочи (862)225-72-31
Астрахань (8512)99-46-04	Калуга (4842)92-23-67	Омск (3812)21-46-40	Ставрополь (8652)20-65-13
Барнаул (3852)73-04-60	Кемерово (3842)65-04-62	Орел (4862)44-53-42	Сургут (3462)77-98-35
Белгород (4722)40-23-64	Киров (8332)68-02-04	Оренбург (3532)37-68-04	Тверь (4822)63-31-35
Брянск (4832)59-03-52	Краснодар (861)203-40-90	Пенза (8412)22-31-16	Томск (3822)98-41-53
Владивосток (423)249-28-31	Красноярск (391)204-63-61	Пермь (342)205-81-47	Тула (4872)74-02-29
Волгоград (844)278-03-48	Курск (4712)77-13-04	Ростов-на-Дону (863)308-18-15	Тюмень (3452)66-21-18
Вологда (8172)26-41-59	Липецк (4742)52-20-81	Рязань (4912)46-61-64	Ульяновск (8422)24-23-59
Воронеж (473)204-51-73	Магнитогорск (3519)55-03-13	Самара (846)206-03-16	Уфа (347)229-48-12
Екатеринбург (343)384-55-89	Москва (495)268-04-70	Санкт-Петербург (812)309-46-40	Хабаровск (4212)92-98-04
Иваново (4932)77-34-06	Мурманск (8152)59-64-93	Саратов (845)249-38-78	Челябинск (351)202-03-61
Ижевск (3412)26-03-58	Набережные Челны (8552)20-53-41	Севастополь (8692)22-31-93	Череповец (8202)49-02-64
Иркутск (395)279-98-46	Нижний Новгород (831)429-08-12	Симферополь (3652)67-13-56	Ярославль (4852)69-52-93
Россия (495)268-04-70	Киргизия (996)312-96-26-47	Казахстан (7172)727-132	